

Item # _____
 Qty # _____
 Model # _____
 Project # _____



DELUXE CUBE ICE MACHINE

18MCSK-289S



FEATURES

1. Energy Star/ DOE/ ETL/ ETLs Certification
2. Exterior with 304 stainless steel
3. High quality compressor and durable fan motors
4. Anticorrosive chemical nickel plated evaporator
5. Automatic fault alert system & cleaning system
6. Digital control panel with ice thickness adjust function
7. Removable air filter and water filter design
8. Environmental Friendly Food Grade Materials
9. With LED illumination

Distributed by masterchefpr.com



787788-2264 787788-2269 787275-1643
 787308-2132
 Royal industrial Park 500 carr 869
 suite 1003 Catano, PR 00966
 @ ventas@masterchefpr.com

DETAILS & SPECIFICATIONS

18MCSK-289S

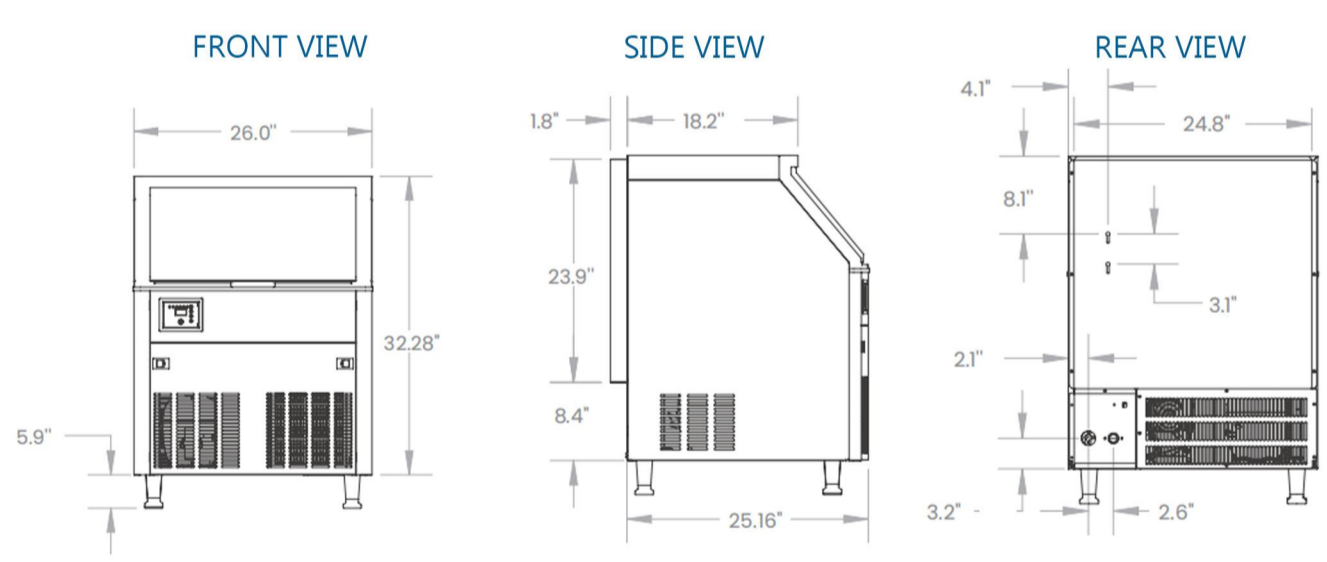

Model	18MCSK-289S
Ice Capacity	280 lbs/24hrs
Ice Storage	80 lbs
Power	726W
Net Weight (lbs)	132 lbs
Gross Weight (lbs)	147 lbs
Width (in)	26 in
Depth (in)	26.96 in
Height (in)	38.18 in
Voltage	110V/60HZ
Refrigerant Type	R290
Packing Dimensions (inches)Width	30.7 in
Packing Dimensions (inches)Depth	29.3 in
Packing Dimensions (inches)Height	35.4 in



Distributed by masterchefpr.com



787788-2264 787788-2269 787275-1643
 787308-2132
 Royal industrial Park 500 carr 869
 suite 1003 Catano, PR 00966
 @ ventas@masterchefpr.com